



PRINTER CONTROLLER (Machine Code: A643)

August 29th, 1996
Final Version

1. OVERALL INFORMATION

1.1 INTRODUCTION

1.1.1 Hardware

The controller adds printer functions to the machine.

The controller has a PCL 5e command interpreter, and the optional printer enhancement unit has a PostScript Level 2 command interpreter.

A hard disk is also available as an optional device for the printer; it is used for storing the PostScript fonts (downloaded from a PC or Macintosh) and the print data for sorting print outs.

The controller has 2 slots for SIMM modules. Up to 32 MB (16 MB x 2) of memory can be installed to improve the printer performance. This will allow for faster image processing, and complex graphics printing without print over run errors.

1.1.2 Software

The following software (driver and utilities) are provided for controlling the printer.

Software	Function
HostPanel for DOS	Gives the user a way to change printer settings, and a way to monitor the printer status under DOS on a PC.
WinPanel for Win 3.1, Win 95	Allows the user to monitor the printer status on a PC with Windows 3.1 or Windows 95 (two separate programs).
PCL driver for Win 3.1, Win 95	Printer driver for using the machine in PCL 5e emulation mode (two separate drivers).
PS2 Driver for Win 3.1, Win 95	Printer driver for using the machine in PostScript Level 2 emulation mode. (two separate drivers)
PPD file for Macintosh	PostScript Printer Description file.

1.2 CONTROLLER SPECIFICATIONS

Item	Specifications
Resolution	300 x 300 dpi, 600 x 600 dpi (selectable)
Smoothing	Yes
Toner Saving Mode	Yes
RAM Capacity	2 MB (Standard) 4 MB (with optional printer enhancement unit) 2 SIMM Slots for 1/2/4/8/16 MB
Emulation	Printer Controller: PCL 5e (LaserJet 4M+) Printer Enhancement Unit (option): PostScript Level 2 (LaserJet 4M+)
Resident Fonts	Printer Controller: 35 Intellifont fonts 10 True Type fonts 1 Bitmap font Printer Enhancement Unit (option): 35 Type 1 fonts
Paper Size	Available from paper cassette: 11 x 17 (L), 8 1/2" x 14" (L), 8 1/2" x 11" (L/S), Executive (L/S), A3 (L), B4 (L), A4 (L/S), B5 (L/S), A5 (S), Folio (L), Foolscap (L), F (L), Free Size (W: 182 - 297 mm/7.2 - 11.7", L: 148 - 432 mm/5.8 - 17") Available from bypass tray: 11 x 17 (L), 8 1/2" x 14" (L), 8 1/2" x 11" (L), 5 1/2 x 8 1/2 (L), Executive (L), A3 (L), B4 (L), A4 (L), B5 (L), A5 (L), Folio (L), Foolscap (L), F (L), Postcard (L), Double Postcard (L), Com 10Env (L), MonarchEnv (L), B5 Env (L), C5 Env (L), C6Env (L), DLEnv (L), Free Size (W: 90 - 297 mm/3.5-11.7") L: 148 - 432 mm/5.8 - 17") Available from duplex tray: 11 x 17 (L), 8 1/2" x 14" (L), 8 1/2" x 11" (L/S), Executive (L/S), A3 (L), B4 (L), A4 (L), B5 (L/S), A5 (S), Folio (L), Foolscap (L), F (L) Note: Duplex printing is not available if the bypass tray is selected.
Host Interface	Printer Controller: Bi-Centronics Parallel Interface x1 RS-232C Serial Interface x1 Printer Enhancement Unit (option): Local Talk Interface x1
Printer Controller Optional Units	Printer Enhancement Unit Hard Disk Drive (540 MB 2.5" IDE) Network Interface Card: Ethernet, Token Ring (IPX/SPX, TCP/IP)

2. DETAILED SECTION DESCRIPTIONS

2.1 BLOCK DIAGRAM (OVERALL)

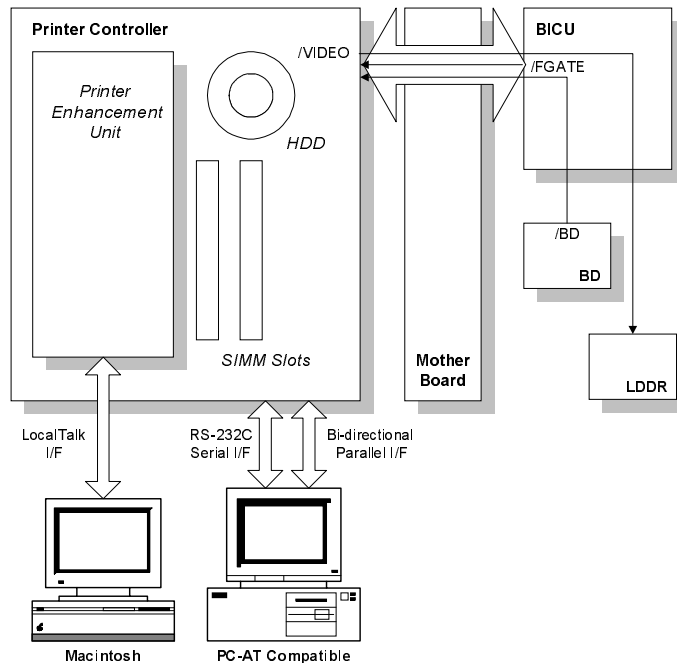

A643V501.wmf

The printer controller is located between the host PC and the machine, and performs the following functions.

Host Interface

- Receives data (consisting of image data and device control codes such as tray selection, duplex print, and resolution selection)
- Sends the machine status, such as error conditions and the paper size loaded in the trays, using the bi-directional parallel interface.
- Handshakes with the PC

NOTE: The printer status can be monitored only when the HostPanel or WinPanel utility is installed on the PC, and the controller and the PC are connected with a bi-centronics cable. If the utility is not installed, or the other interfaces (RS-232C or LocalTalk) are used for connection to the PC or Macintosh, this feature is not available.

Internal Controller

- Buffers data received from the PC
- Processes the data sent from the PC and makes the video data using the PCL or PostScript interpreter accordingly (toner saving and edge enhancement functions affect the data when processing.)
- Emulation switching (PS/PCL) if auto switching mode is selected while the printer enhancement unit is installed
- Auto input tray switching

Machine Interface

The function of these signals are as follows.

- Receives status data from the machine
- Receives timing signals for horizontal and vertical image synchronization
- Sends commands to the machine (e.g. tray selection, front panel display in printer mode)
- Sends the video data.

Note that the video data goes through the BICU, and directly drives the laser diode. That is, all of the data processing is done by the controller, and the BICU's processing functions are not used.

2.2 INTERFACE

2.2.1 Host Interface

Bi-Directional Parallel Interface

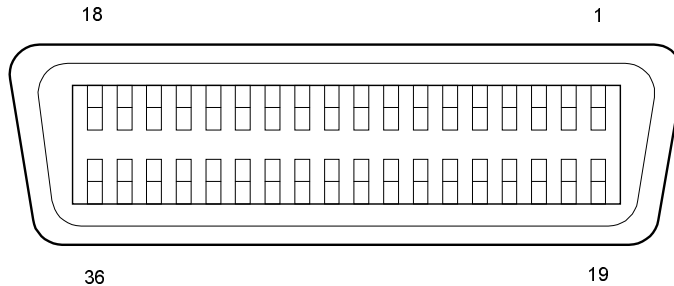

A643D502.wmf

A 36 pin bi-directional parallel interface connector (female).

The bi-directional parallel interface on the controller works in the 3 modes; compatible, nibble, and ECP modes (these modes are standardized by IEEE 1284).

SIGNAL PIN	SIGNAL NAME		
	STD (I/O)	NIBBLE (I/O)	ECP (I/O)
1	/STROBE (I)	/STROBE (I)	HostClk (I)
2-9	DATA1-8 (I)	NOT USED	DATA1-8 (I/O)
10	/ACK (O)	PtrClk (O)	PeriphClk (O)
11	BUSY (O)	PtrBusy (O)	PeriphAck (O)
12	PE (O)	AckDataReq (O)	/AckReverse (O)
13	SELECT (O)	Xflag (O)	Xflag (O)
14	/AUTOFEED (I)	HostBusy (I)	HostAck (I)
15	NC	<--	<--
16	GND	<--	<--
17	CHASSIS GND	<--	<--
18	NC	<--	<--
19-30	GND	<--	<--
31	/INIT (I)	/INIT (I)	/ReverseRequest (I)
32	/ERROR (O)	DataAvail (O)	/PeriphRequest (O)
33	GND	<--	<--
34	NC	<--	<--
35	+5V	<--	<--
36	/SELECTIN (I)	1284Active (I)	1284Active (I)

RS-232C Interface

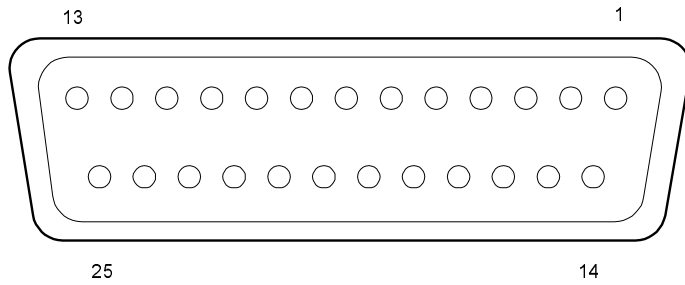

A643D501.wmf

A 25 pin D-SUB female connector (ISO 2110)

PIN NO.	SIGNAL NAME	DESCRIPTION
2	STXD	Serial transmit data
3	SRXD	Serial receive data
4	+10V	
6	SDSR	Data set ready
20	SDTR	Data terminal ready

LocalTalk interface

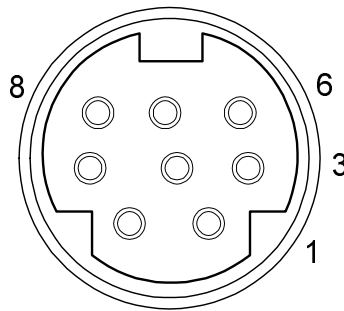

A643D503.wmf

An 8 pin D-SUB female connector (DIN-8).

PIN NO.	SIGNAL NAME	DESCRIPTION
1	GND	
2	HSK (I)	Handshake
3	TXD- (O)	Transmit data –
4	GND	Signal ground
5	RXD- (I)	Receive data –
6	TXD+ (O)	Transmit data
7	N.C.	No connection
8	RXD+ (I)	Receive data +

2.2.2 Machine Interface

The pin assignment of the interface is as follows.

PIN NO.	SIGNAL NAME	DESCRIPTION
A1	/EBD (I)	Beam detection signal sent from the machine. Used for line synchronization.
A2	EVDO (O)	Binary video data. Goes through the BICU to LDDR.
A3	/EVSYNC (I)	Vertical gate signal made by the BICU according to the selected paper size.
A4	/ESTS (I)	Status line from the machine.
A5	ECMD (O)	Command line to the machine.
A6-10	VCC	Power supply from the machine.
B1-3	N.C.	No connection
B4	/ESBSY (O)	Indicates that the controller can receive the status.

2.3 BLOCK DIAGRAM (INTERNAL)

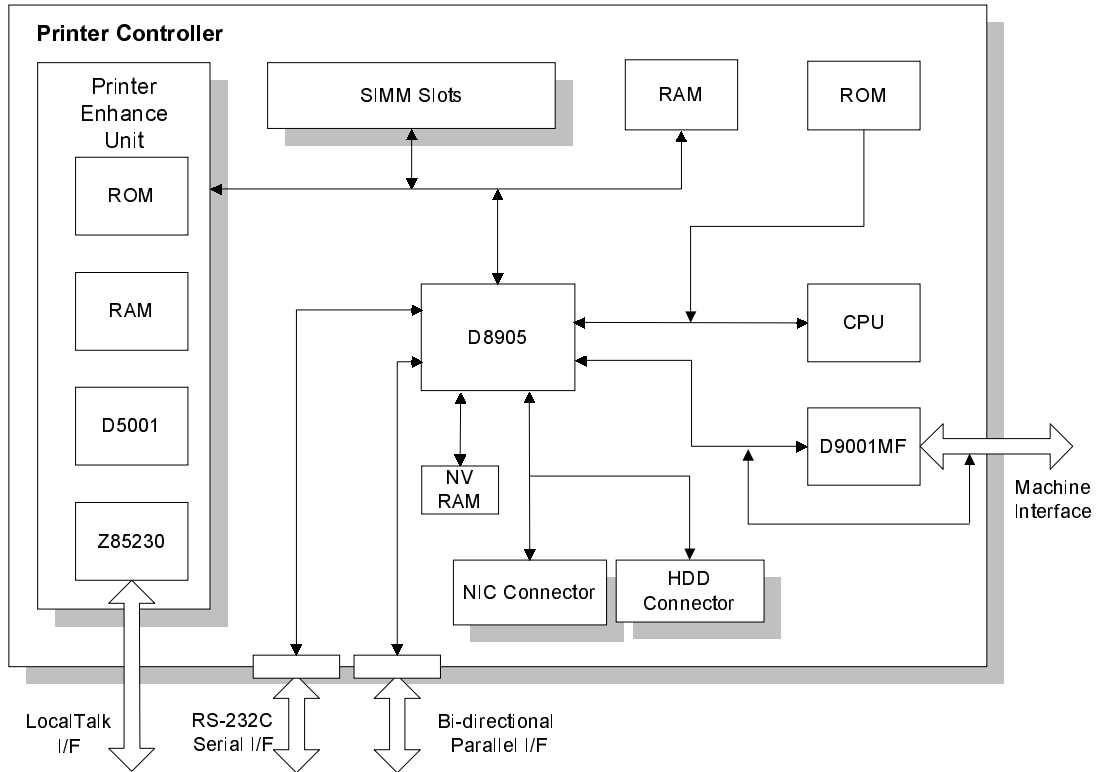

A643V500.wmf

2.3.1 Printer Controller

CPU

An Intel i960JF-25 RISC CPU is used. A 50Mhz oscillator is used as the clock source for both the i960JF-25 and D8905. However, the clock is used by the i960JF-25 after it is divided by 2 (25Mhz). The PST5920 is used to provide the system reset for the CPU and D8905.

D8905

The D8905 is an ASIC which has the following functions.

- DRAM controller
- Video controller
- ROM and I/O interface
- Three I/O DMA channels
- Interrupt controller
- Rotator
- Bi-directional parallel interface
- Two UARTs
- Decoder

D9001MF

The D9001MF is an ASIC which has the following functions.

- Normal mode, to carry out edge smoothing on 600 dpi video data
- Adaptive mode, to convert 300 dpi data to 600 dpi and make edge smoothing
- Converts data for toner saving

RAM

Two Mbytes of DRAM are provided on the board. It consists of 4 pieces of 4 Mbit fast page mode DRAM (256k x 16 DRAM).

NV RAM

The board contains a 512-byte NV RAM. It is used for holding parameters (such as the baud rate, the printer name, and the default mode setting), that need to be kept after the machine is switched off.

ROM

Two ROM chips (1M x 16) are used for storing the PCL code and font data, test page data, and multi-language display message codes for the front panel (4 megabytes). Page mode ROMs are used for optimum performance.

SIMM Slots

Two SIMM slots are provided for RAM expansion. 1, 2, 4, 8, or 16 MByte standard SIMM modules can be installed. As a result, up to 32 Mbyte of RAM are installable (16 Mbyte x 2).

Network Interface

One interface slot is provided for installing a network interface card (NIC).

Parallel Interface

The D8905 provides a bi-directional parallel interface (IEEE 1284). To protect parallel communication from noise, the circuit for control signals (like STROBE and AUTOFEED) uses Schmidt trigger TTL.

Serial Interface

RS-232C is supported, using the UART provided in the D8905.

IDE Hard Disk Interface

Chip select and address lines from the D8905 are used for providing the necessary signals to the hard disk. The 16-bit IDE data line is connected to the D8905 for the byte-to-word packing.

Engine Interface

Another UART unit in the D8905 is used for serial communication with the machine.

Jumpers (Printer Controller Board)

JP1:

Default is open (factory use only)

JP2, JP3:

Both opened when installing the printer enhancement unit. Both short for the printer controller only configuration. Default is both short.

JP4:

Switches between ROM types.

Open: Normal (OTP) ROM

Short: Page Mode (mask) ROM

Note: Normal (OTP) ROM has a label on the top of the chip to distinguish it from page mode (mask) ROM (which has no label).

2.3.2 Printer Enhancement Unit

D5001

A D5001 ASIC is used in this unit. It performs the following functions.

- Data compression/reconstruction
- Halftone painting
- Horizontal line filling
- Right and left edge clipping
- Line drawing with or without pattern

Z85230

The Z85230 is an enhancement serial communication controller (ESCC).

ROM

Two Mbytes of ROM are used for storing the PostScript Level 2 code and the font data.

RAM

Two Mbytes of DRAM are provided on the board. It consists of 4 pieces of 4 Mbit fast page mode DRAM (256k x 16 DRAM) as well as the printer controller. Together with the 2 MB DRAM on the printer controller, a minimum 4 Mbytes of memory is available when the printer enhancement unit is installed.

2.4 Hard Disk Drive

Operation

The disk is formatted if the "HD initialize" function is used (this is a user function). It takes about 15 minutes. "Formatting HD" is indicated during formatting. Two partitions are made when formatting. The ratio of the first to the second is 1:4. The first partition is for the PostScript fonts (downloaded outline fonts and cached bitmap fonts) and the second partition is for the sorting function.

To maintain the reliability of the disk drive and the head, if the hard disk does not operate for more than 10 minutes, the controller stops the disk motor and does a seek operation. If inoperation continues, the seek operation is performed every 10 minutes.

If any bad sectors are detected during hard disk operation, the sector will be skipped. The controller will find the next good sector.

If the hard disk fails, the sort function will disappear when the machine is switched off/on. Also, the "HDD Installed" message will disappear from the test page.

2.5 Features

2.5.1 Sorting Function

If "Sorting" is turned on and a multicopy job is printed, the rendered image of each page in the job is stored on the disk first. The controller then sends page images to the machine page by page until all copies in this job are printed out.

If the face up tray is selected as the output tray, the page order sent to the engine will be reversed (last page first).

Even if "Sorting" is set to on, there are two cases in which the print job does not go through the hard disk. One case is when there is only one page in the print job and the face up output tray is selected. The other case is when there is only one set of pages in the print job and the face down output tray is selected.

2.5.2 Duplex Printing

If there is enough memory to store the data of six pages and the controller can process the data faster than the printing speed (this depends on the processed data), the printing sequence is the three-sheet batch mode. The printing sequence in this mode is as follows:

2nd page/4th page/1st page/6th page/3rd page/8th page/5th page/10th page...

If the memory or the controller does not satisfy the above conditions, the controller automatically shifts down the printing speed to the two-sheet batch mode or the one-sheet batch mode. (For double letter and A3 size paper, only one-sheet mode is available.) Each printing sequence is as follows.

Two-sheet batch mode:

2nd page/4th page/1st page/3rd page/6th page/8th page/5th page/7th page/...

One-sheet batch mode:

2nd page/1st page/4th page/3rd page/6th page/5th page/...

NOTE: The printer controller goes through this determination sequence for each page, not just the first few. Therefore, the duplex batch mode may change several times during a single copy job, depending on the specific qualities of each page's data.

The following flow chart demonstrates this process for the first few pages.

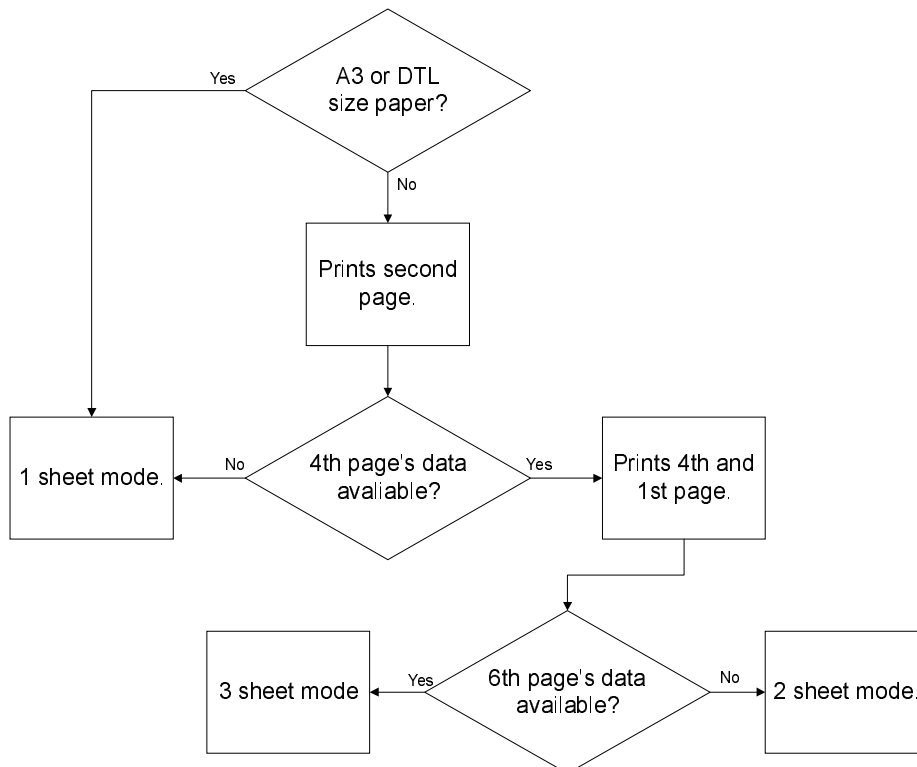

A643D500.wmf

3. INSTALLATION

⚠ CAUTION

Before installing an optional unit, do the following.

1. If a fax unit has been installed, print out all messages stored in the memory, the lists of user-programmed items, and the system parameter list.
2. Turn off the main and the ac switches, and disconnect the power cord.

3.1 PRINTER CONTROLLER

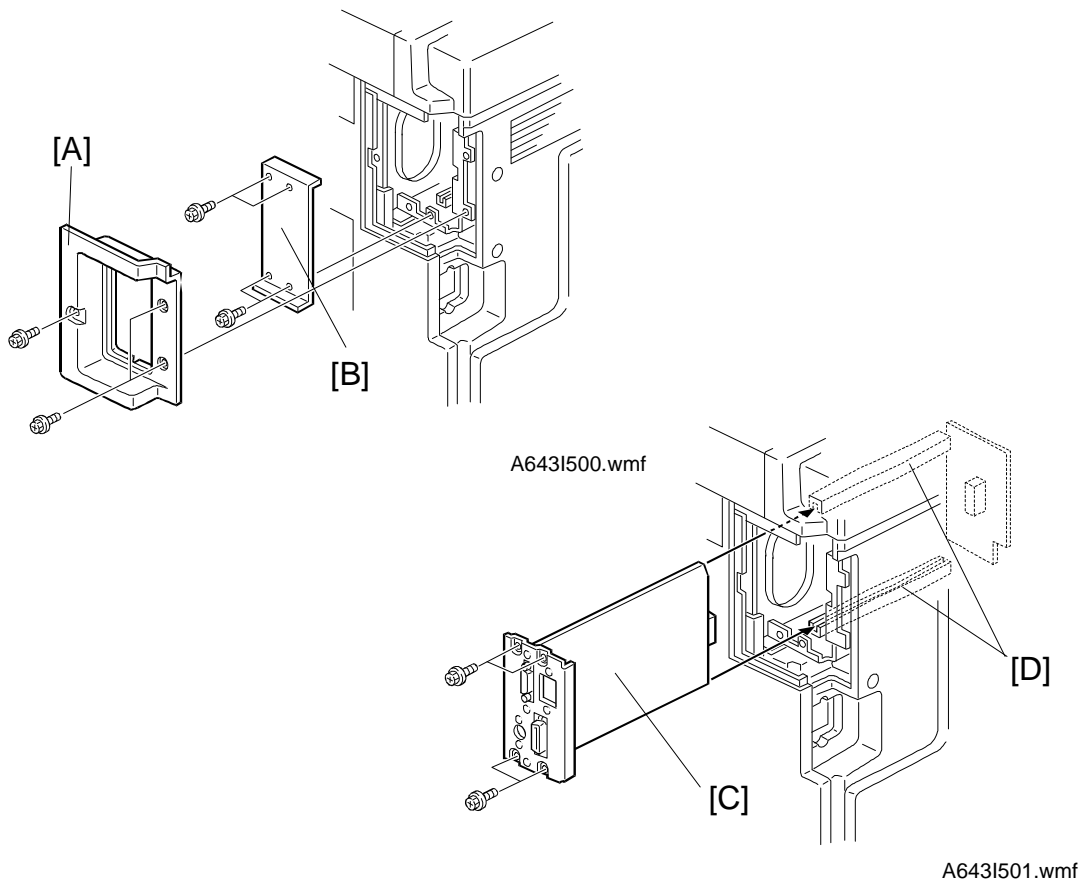

1. Remove the interface cover [A] (3 screws), and the inner cover [B] (4 screws).
2. Install the controller board [C] along the guides [D] (4 screws).
3. Replace the interface cover [A] (3 screws).

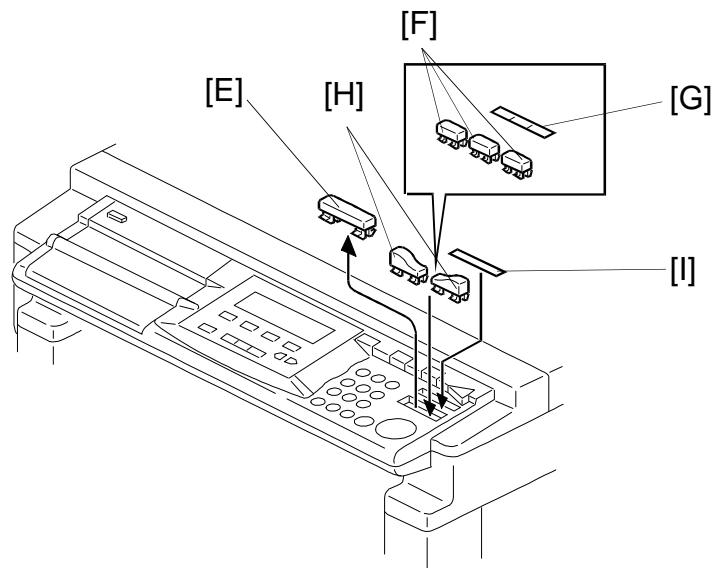

A1981014.wmf

4. Remove the key [E].
5. If the machine has the facsimile option, install the keys [F] and the decal [G] as shown. The decal [G] has "Copy", "Printer", and "Facsimile" printed on it. If the machine does not have the facsimile option, install the keys [H] and the decal [I] as shown. The decal [I] has "Copy" and "Printer" printed on it.

3.2 PRINTER ENHANCEMENT UNIT

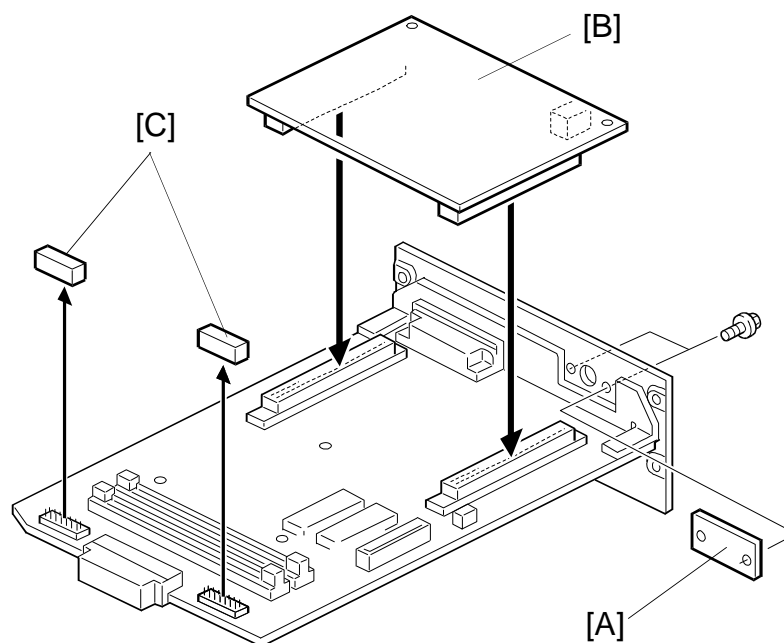

A643I505.wmf

NOTE: If the printer controller is already installed, remove the printer controller before attempting to install the printer enhancement unit.

1. Remove the bracket [A] (2 screws).
2. Connect the printer enhancement unit [B] (2 connectors).
3. Remove the two short pins [C] from JP2 and JP3 on the printer controller board.
4. Install the printer controller along the guides (4 screws). (See 3.1. Printer Controller.)
5. Replace the interface cover (3 screws). (See 3.1. Printer Controller.)

3.3 HARD DISK DRIVE

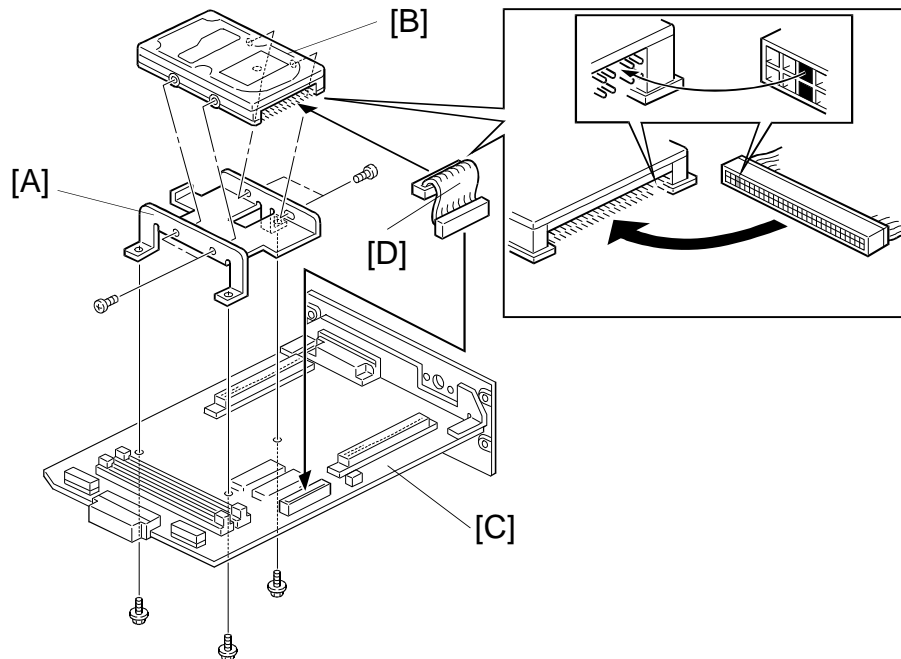

A6431503.wmf

NOTE: If the printer controller is already installed, remove the printer controller before attempting to install the hard disk drive.

1. Attach the bracket [A] to the hard disk drive [B] (4 screws).
2. Attach the hard disk drive assembly to the controller board [C] (3 screws).
3. Connect the flat cable connector [D] from the hard disk drive assembly to the controller board (2 connectors).

NOTE: Two of the holes on one end of the cable connector are filled with pins. Connect this end to the HDD connector.

4. Install the printer controller assembly along the guides (see 3.1. Printer Controller).
5. Replace the interface cover (see 3.1. Printer Controller).

3.4 SIMM MODULE

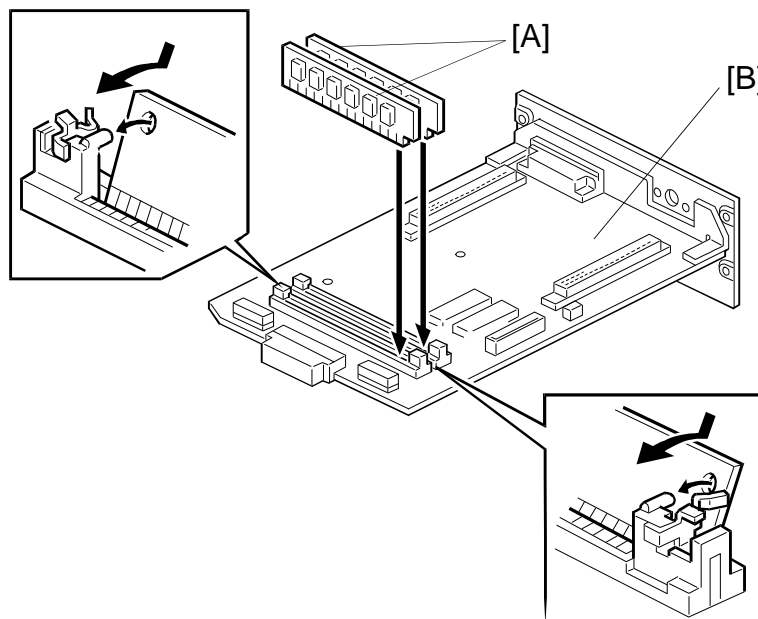

A643I504.wmf

- NOTE:** 1) If the printer controller is already installed, remove the printer controller before attempting to install the SIMM module.
 2) Before install the SIMM module, confirm that it satisfies the requirements below.

SIMM Requirements

Type	PC Compatible
Number of pins	72
Access speed	70 ns or faster
Capacity	1, 2, 4, 8, or 16 MB
Parity	Any OK

1. Install the SIMM module(s) [A] in the slot(s) (J1, J2) on the printer controller [B].

NOTE: If you install only one SIMM module, it may be installed in either slot J1 or J2.

2. Install the printer controller along the guides (4 screws). (See 3.1. Printer Controller.)
3. Replace the interface cover (3 screws). (See 3.1. Printer Controller.)

3.5 CONNECTING THE INTERFACE CABLE

3.5.1 Parallel Interface

A bi-directional parallel cable is required to connect the printer controller to a host PC parallel port.

3.5.2 Serial (RS-232C) Interface

An RS-232C cross cable is required to connect the printer controller to a host PC serial port.

The figure below shows the wiring diagram of the RS-232C cross cable.

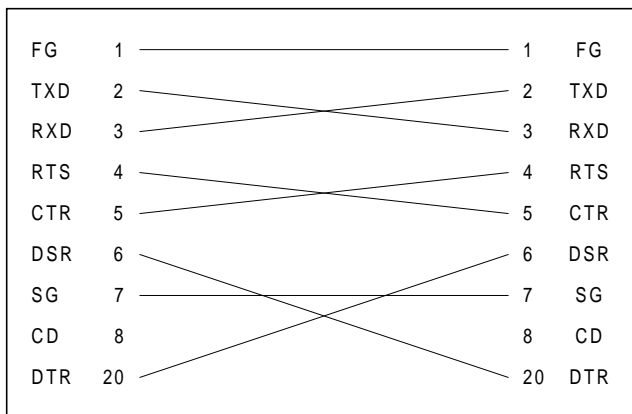

A643I508.wmf

3.5.3 LocalTalk Interface

A LocalTalk cable is required to connect the Printer Enhancement Unit to a host Macintosh printer port.

3.6 CHECKING THE CONNECTIONS

3.6.1 Connection Between Printer Controller (and related options; Printer Enhancement Unit, Hard Disk Drive, SIMM) and Copier

1. Plug in the power cord and turn on the ac and main switches.
2. Press the Printer key to select the printer function. The LCD should display "Ready PCL (PS or Auto)".
3. Press "Online". The LCD displays the menu.
4. Select "Test".
5. Select "Cont Self Test".
6. Press "Start" to print the test pages, then press "Cancel" to stop.

NOTE: For more detailed information about the operation panel settings, refer to the operation manual.

The test page is like the following.

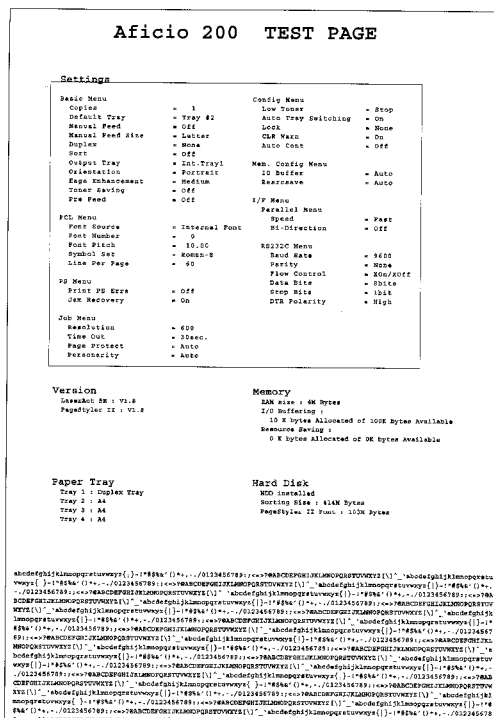

A6431507.img

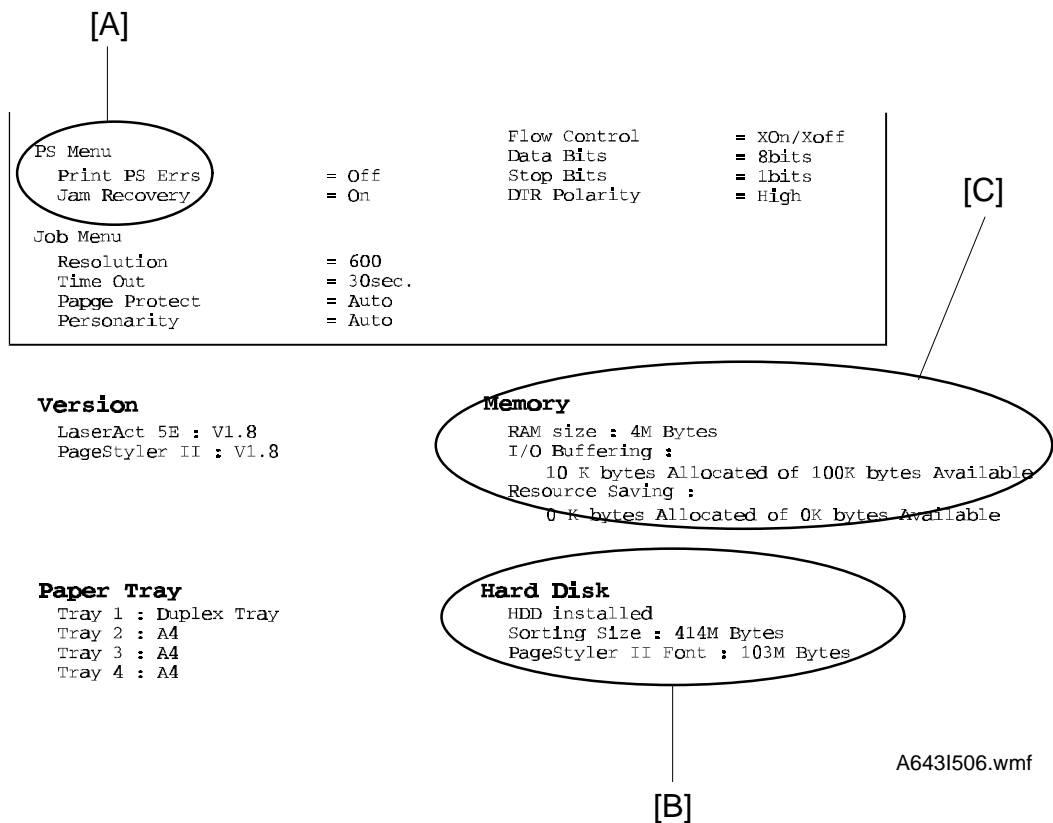

Check the following:

- For the Printer Controller, confirm that the machine prints the test page
- For the Printer Enhancement Unit, confirm that the test page includes "PS Menu" [A] in the "Settings" box.
- For the Hard Disk Drive, confirm the test page includes "HDD installed" [B].
- For the SIMM Module, confirm that "RAM SIZE" [C] printed on the test page shows the size of the module just installed, plus 2 MBytes (without Printer Enhancement Unit), or plus 4 MBytes (with Printer Enhancement Unit)?

If any problems occur in the above steps, reinstall the printer controller and other options, then redo the tests.

3.6.2 Connection Between Printer Controller (Printer Enhancement Unit) and Host PC or Macintosh

Important:

It is not recommended for service technicians to operate the customer's computer. This is to avoid any liability of loss to the customer's data files.

The following procedures are explained only for testing purposes.

– DOS Based Computers –

1. Make sure that the printer cable is properly connected.
2. Turn on the machine, then turn on the computer.
3. Press the printer key to select the printer mode.
4. Make sure that the printer controller is online (indicating "Ready PCL" or "Ready Auto").
5. After DOS has started, type the following at the C:/> prompt:
 PRINT CONFIG.SYS (then return)
 The computer displays the following:
 NAME OF LIST DEVICE (PRN); (then return)
 Then, type the following:
 LPT1: (then return)
 The config.sys file will be printed from the machine.

2. Mac OS Computer

1. Make sure that the printer cable is properly connected.
2. Turn on the machine, then turn on the computer.
3. Press the printer key to select the printer mode.
4. Make sure that the printer controller is online (indicating "Ready Auto").
5. After Mac OS completes the initialization, make sure that LocalTalk is selected as a network connection method. (To check it, select "Apple Menu"/"Control Panel"/"Network".)
6. Open the "Chooser" window in the "Apple Menu". Make sure that AppleTalk is active. Select the LaserWriter8 driver and the printer named "Aficio 200" .
7. Select the print screen in the file menu and click OK.
8. A hard copy of the screen will be printed.

4. SERVICE TABLES AND PROCEDURES

4.1 SERVICE REMARKS

⚠ GENERAL CAUTION

Do not turn off the machine or switch the controller off line when the data LED is blinking or is lit or the data which has been sent to the controller will be lost. If you need to do this, ask the customer for consent.

4.1.1 Hard Disk Initialization

The controller has a "HD initialize" function (if an optional hard disk is installed). If the "HD initialize" function is used, the downloaded fonts stored on the disk will be erased.

4.1.2 About Settings

- Even if you set the operation mode at the front panel, the software setting always overrides it. When you check the printer function by printing from the host, be sure that the appropriate setting has been made by the software.
- If you replace the controller or use the "Menu Reset" function, the settings will be reset to the factory defaults. So you need to print the test page before doing this to have a list of the current settings. Then set each menu item to the previous settings.

5. TROUBLESHOOTING

General Information

To solve a problem, you need to classify the cause of the problem into one of the following groups.

1. Operation

- a. Machine setting error
- b. User application setting error

2. Hardware

- a. Hardware error in the machine
- b. Hardware error in the controller (or the related options).

3. Software

- a. Controller (or printer enhancement unit) bug
- b. Printer driver bug
- c. Application software bug

4. Operating Condition

- a. Environment (power supply, temperature, humidity, dust, electrical noise, etc.)
- b. Supplies (e.g. paper)

You need to get the following information before troubleshooting each case.

- 1-a Test page and print sample
- 1-b. Application settings and print sample
- 2. Error code
- 3. Print sample and occurrence conditions
- 4. Operating conditions

5.1 ERROR MESSAGES

In the printer mode, the controller controls displays on the operation panel. The service call error messages generated by the printer controller and the related options shown below. When these errors occur, the printer error LED lights and the front panel displays an error message. Note that the panel indicates these errors only when the printer mode is selected. If HostPanel or WinPanel has been installed on a PC, the status can be monitored on the PC display.

CALL SERVICE ERRORS

- SC2100
Printer controller ROM checksum error
- SC2101
Printer controller RAM error
- SC2105
Printer controller NV RAM error
- SC2150
Printer controller CPU error
- SC2200
Printer SIMM module error (#1 slot)
- SC2201
Printer SIMM module error (#2 slot)
- SC2300
Printer enhancement unit ROM checksum error.
- SC2301
Printer enhancement unit RAM error.

5.2 HARDWARE ERRORS

If the machine indicates an error message in the printer mode, check and correct the following.

1. Does the machine work in copy mode?
2. Is the controller (or the related options) installed correctly?

If the problem still occurs, replace the unit that corresponds to the error.

5.3 CONNECTION ERRORS

If you have a problem regarding the controller connection with the machine or the host (hardware or software), you may have the following symptoms.

1. The online LED does not light.
2. The machine does not go into the printer mode if the printer key is pressed.
3. The data LED on the front panel does not light or blink.
4. The machine does not print, though the data LED lights or blinks.

Check and correct the following first.

1. Is the controller (or the related options) installed correctly?
2. Is the printer controller online?
3. Is the printer cable correctly connected?
4. Is the proper printer cable used?
5. Are the printer interface and the host's printer port set up correctly? (e.g. flow control, transfer speed, stop bit, etc.)
6. Does the emulation mode of the printer match the selected driver?

If the connection problem still occurs after correcting the above problems, replace the controller (if the parallel or the RS-232C interface is used) or the printer enhancement unit (if the LocalTalk interface is used).

5.4 IMAGE PROBLEMS

If you have a problem with the printed image, first check and correct the following items:

1. Is the printer cable correctly connected?
2. Is the proper printer cable used?
3. Does the image problem occur only in printer mode? (Is the image in copy mode OK?)
4. Does the emulation mode of the printer match the selected driver?
5. Is the same font used between the printer and the software?
6. Is toner saving mode on? (If so, turn it off and recheck.)

If the problem still occurs after correcting the above items, proceed as follows:

1. Does the problem occur only when printing a downloaded font?
→If yes, reinstall the font.
2. Is "Memory Overflow" or "Print Overrun" displayed during printing? (The printed image will be partially blank in this case.)
→If yes, more memory needs to be installed.
3. Does the problem occur when you print the PCL font list?
→If yes, replace the controller.
4. Does the problem occur when you print the PostScript font list?
→If yes, replace the printer enhancement unit.